

This item has been electronically signed and sealed by Gary Hartman on 6/10/2021 using a SHA authentication code.

Printed copies of this document are not considered signed and sealed and the SHA authentication code must be verified on any electronic copies.

EVALUATOR
Gary Hartman, P.E. (ANE11725)
11532 Balintore Dr.
Riverview, FL 33579

MANUFACTURING LOCATIONS
The Murus Company
3234 Route 549
Mansfield, PA 16933

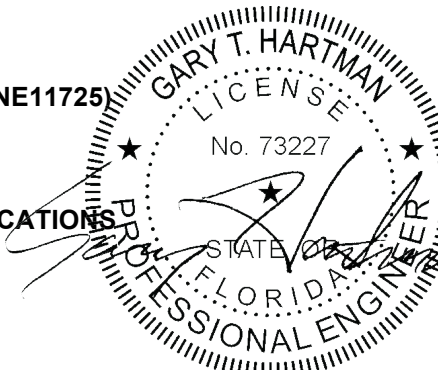

1. SUBJECT

1.1 **Murus PUR Structural Insulated Panels. Wall Panels**
4-ft to 24-ft long, 4-5/8-in. to 6-5/8-in. thick.

2. SCOPE

The Evaluator has evaluated the above product(s) for compliance with the applicable sections of the following codes:

- 2.1 Florida Building Code Seventh Edition (2020) Building
- 2.2 State of Florida Rule 61 G 20-3, FAC, Product Approval
- 2.3 Compliance Method: Evaluation Report from a Licensed Florida Professional Engineer
- 2.4 The Evaluator has evaluated the above product for Structural performance under axial, transverse and in-plane shear loads.

3. USES

- 3.1 **General.** *Murus PUR SIPs* are used as structural insulated wall panels capable of resisting transverse, axial and in-plane shear loads.
- 3.2 **Construction Types.** *Murus PUR SIPs* shall be considered combustible building elements when determining the Type of Construction in accordance with Florida Building Code Seventh Edition (2020) Building Chapter 6.
- 3.3 **Fire Resistive Assemblies.** *Murus PUR SIPs* shall not be used as part of a fire-rated assembly unless suitable evidence and details are submitted and approved by the authority having jurisdiction.
- 3.4 **High Velocity Hurricane Zone.** The subject of this report has not been evaluated for use in high velocity hurricane zone (HVHZ).

4. DESCRIPTION

4.1 **General.** *Murus PUR SIPs* are factory-assembled, engineered-wood faced, structural insulated panels (SIPs) with foamed-in-place polyurethane (PUR) foam plastic core. The product is intended for use as load-bearing or non-load bearing wall components. *Murus PUR SIPs* are available in 4-5/8-in. through 6-5/8-in. overall thicknesses and are custom

made to the specifications for each use. The maximum product size is 4-ft wide and 24-ft long.

4.2 Materials

4.2.1 **Facing.** The facing consists of two single-ply oriented strand board (OSB) facings a minimum of 7/16-in. thick conforming to DOC PS 2-10, Exposure 1, Rated Sheathing with a span index of 24/16. Panels are manufactured with the facing strength axis oriented parallel to the direction of product bending.

4.2.2 **Core.** The foamed-in-place polyurethane foam core has a minimum 2.2 pcf in-place density and self-adheres to the facing. The foam core has a flame spread index not exceeding 25 and a smoke-developed index not exceeding 450 when tested in accordance with ASTM E84.

4.2.3 **Material Sources.** The facing and core materials used in the construction of *Murus PUR SIPs* are from approved sources as identified in the in-plant quality system documentation.

4.2.4 **Splines.** *Murus PUR SIPs* are interconnected with surface splines or a cam-lock system (Figure 1). Connections using dimensional lumber splines or engineered structural splines are not specifically addressed in this report and must be designed in accordance with accepted engineering practice to meet applicable code requirements.

5. DESIGN

5.1 **Overall Structural System.** The scope of this report is limited to the evaluation of the SIP wall component. Panel connections and other details related to incorporation of the product into the overall structural system of a building are beyond the scope of this report.

5.2 **Design Approval.** Where required by the authority having jurisdiction, structures using *Murus PUR SIPs* shall be designed by a registered design professional. Construction documents, including engineering calculations and drawings providing floor plans, window details, door details and connector details, shall be submitted to the code official when application is made for a permit. The individual preparing such documents shall possess the necessary qualifications as required by the applicable code and the professional registration laws of the state of Florida. Approved construction documents shall be available at all times on the jobsite during installation.

5.3 **Design Loads.** Design loads to be resisted by the product shall be as required under the applicable code. Loads on the panels shall not exceed the loads noted in this report. Where loading conditions result in superimposed stresses, the sum of the ratio of actual loads over allowable loads shall not exceed one. Calculations demonstrating that the loads

This Engineering Evaluation Report is intended to indicate that the Evaluator has evaluated the product(s) herein based on the information available at the time of report issuance. The Evaluator reserves the right to modify, amend or withdrawal this report at any time based on information that becomes available subsequent to the issuance of this report. The Evaluator makes no warranty, either expressed or implied, regarding the product covered by this report.

applied are less than the allowable loads described in this report shall be submitted to the code official for approval.

5.4 Allowable Loads. Allowable axial, transverse, and in-plane shear loads may be calculated using the panel properties provided in Tables 1 and 2 or selected from Tables 3 through 7. For loading conditions not specifically addressed herein, structural members designed in accordance with accepted engineering practice shall be provided to meet applicable code requirements.

5.5 Concentrated Loads. Axial loads shall be applied to the product through continuous members such as structural insulated roof or floor panels or repetitive members such as joists, trusses or rafters spaced at regular intervals of 24-in. on center or less. Such members shall be fastened to a rim board or similar member to distribute the load to the product. For other loading conditions, reinforcement shall be provided. This reinforcement shall be designed in accordance with accepted engineering practice.

5.6 Eccentric and Side Loads. Axial loads shall be applied concentrically to the top of the product. Loads shall not be applied eccentrically or through framing attached to one side of the panel (such as balloon framing) except where additional engineering documentation is provided.

5.7 Openings. Openings in panels shall be reinforced with wood or steel designed in accordance with accepted engineering practice to resist all loads applied to the opening as required by the adopted code. Details for door and window openings shall be provided to clarify the manner of supporting axial, transverse and/or in-plane shear loads at openings. Such details shall be subject to approval by the local authority having jurisdiction.

5.8 In-Plane Shear Design. Shear walls shall be sized to resist all code required wind and seismic loads without exceeding the allowable loads provided herein. Shear wall chords, hold-downs and connections to transfer shear forces between the wall and surrounding structure shall be designed in accordance with accepted engineering practice. Allowable strengths for SIP shear walls with structural splines along each panel edge shall be designed in accordance with accepted engineering practice and are subject to the limitations for wood sheathed shear walls.

5.9 Seismic Design Categories A, B and C. Use of the shear wall configurations in Table 4 is limited to structures in Seismic Design Categories A, B and C. Where SIPs are used to resist seismic forces the following factors shall be used for design: Response Modification Coefficient, $R = 2.0$; System Overstrength Factor, $\Omega_0 = 2.5$; Deflection Amplification Factor, $C_d = 2.0$. The maximum panel height-to-width ratio shall be 2:1.

5.10 Combined Loads. Panels subjected to any combination of transverse, axial or in-plane shear loads shall be analyzed utilizing a straight line interaction.

6. INSTALLATION

6.1 General. *Murus PUR SIPs* shall be fabricated, identified, and erected in accordance with this report, the approved construction documents and the applicable code. In the event of a conflict between the manufacturer's published installation instructions and this report, this report shall govern. Approved construction documents shall be available at all times on the jobsite during installation.

6.2 Splines. *Murus PUR SIPs* are interconnected at the panel edges using a surface spline or cam-lock system, as shown in Figure 1. When cam-locks are used to connect panels, the cam-locks are spaced no less than 24 in. on center. All joints shall be sealed in accordance with the SIP manufacturer's installation instructions.

6.3 Plates. The top and bottom plates of the panels shall be dimensional or engineered lumber sized to match the core thickness of the panel. The plates shall be secured using not less than 0.131-in. x 2-1/2-in. nails, spaced 6 in. on center on both sides of the panel or an approved equivalent fastener. A second top plate of 1-1/8-in. minimum thickness dimensional or engineered lumber with a specific gravity of 0.42 that is cut to the full thickness of the panel shall be secured to the first top plate using 0.162-in. x 3-1/2-in. nails or an approved equivalent fastener.

6.4 Cutting and Notching. No field cutting or routing of the panels shall be permitted except as shown on approved construction documents from a registered design professional.

6.5 Protection from Decay. SIPs that rest on exterior foundation walls shall not be located within 8 in. of exposed earth. SIPs supported by concrete or masonry that is in direct contact with earth shall be protected from the concrete or masonry by a moisture barrier.

6.6 Protection from Termites. In areas subject to damage from termites, SIPs shall be protected from termites using an approved method. Panels shall not be installed below grade or in contact with earth.

6.7 Heat-Producing Fixtures. Heat-producing fixtures shall not be installed in the panels unless protected by a method approved by the code official or documented in test reports. This limitation shall not be interpreted to prohibit heat-producing elements with suitable protection.

This Engineering Evaluation Report is intended to indicate that the Evaluator has evaluated the product(s) herein based on the information available at the time of report issuance. The Evaluator reserves the right to modify, amend or withdrawal this report at any time based on information that becomes available subsequent to the issuance of this report. The Evaluator makes no warranty, either expressed or implied, regarding the product covered by this report.

6.8 Voids and Holes

6.8.1 Voids in Core. In lieu of openings designed in accordance with section 5.7, the following voids are permitted. Voids may be provided in the panel core during fabrication at predetermined locations only. Voids parallel to the panel span shall be limited to a single 1 in. maximum diameter hole. Such voids shall be spaced a minimum of 4 ft on center measured perpendicular to the panel span. Two 1/2-in. diameter holes may be substituted for the single 1-in. hole provided they are maintained parallel and within 2 in. of each other. Voids perpendicular to the panel span shall be limited to a single 1-in. maximum diameter hole placed not closer than 18 in. from the support. Additional voids in the same direction shall be spaced not less than 24 in. on center.

6.8.2 Holes in Panels. Holes may be placed in panels during fabrication at predetermined locations only. Holes shall be limited to 4 in. by 4 in. square. The minimum distance between holes shall not be less than 4 ft on center measured perpendicular to the panel span and 24 in. on center measured parallel to the panel span. Not more than three holes shall be permitted in a single line parallel to the panel span. The holes may intersect voids permitted elsewhere in this report.

6.9 Panel Cladding

6.9.1 Exterior Wall Covering. Panels shall be covered on the exterior by a water-resistive barrier as required by the applicable code. The water-resistive barrier shall be attached with flashing in such a manner as to provide a continuous water-resistive barrier behind the exterior wall veneer. The exterior facing of the SIP wall shall be covered with weather protection as required by the building code or other approved materials.

6.9.2 Interior Finish. The foam plastic core shall be separated from the interior of the building by an approved thermal barrier of 1/2-in. gypsum wallboard or equivalent thermal barrier where required by Florida Building Code Seventh Edition (2020) Building, Section 2603.4.

7. CONDITIONS OF USE

Murus PUR SIPs as described in this report comply with the codes listed in Section 2 above, subject to the following conditions:

7.1 Installation complies with this report and the approved construction documents.

7.2 This report applies only to the panel thicknesses specifically listed herein.

7.3 In-use panel heights/spans shall not exceed the values listed herein. Extrapolation beyond the values listed herein is not permitted.

7.4 The panels are manufactured in the production facilities listed in this report.

8. EVIDENCE SUBMITTED

The Evaluator has examined the following evidence to evaluate this product:

8.1 Test reports:

- 8.1.1** ASTM E72-15 Section 11, Transverse Load, NTA, Inc. [FBC:TST3478], 6/17/16, Test Report Numbers:
- 8.1.1.1 MUR(660)092815-20, 48-in. x 96-in. x 4.5-in.
 - 8.1.1.2 MUR(660)092815-21, 48-in. x 96-in. x 6.5-in.
 - 8.1.1.3 MUR(660)092815-22, 48-in. x 288-in. x 4.5-in. MUR(660)092815-23, 48-in. x 288-in. x 5.5-in. , 6/17/16
 - 8.1.1.4 MUR(660)092815-24, 48-in. x 288-in. x 6.5-in. MUR(660)092815-25, 48-in. x 96-in. x 4.5-in. (zero bearing)
 - 8.1.1.5 MUR(660)092815-26, 48-in. x 96-in. x 6.5-in. (zero bearing)
 - 8.1.1.6 MUR(660)122115-15, 48-in. x 96-in. x 6.5-in.
- 8.1.2** ASTM E72-15 Section 11, Transverse Load, NTA, Inc. [FBC:TST3478], 11/22/16, Test Report Numbers:
- 8.1.2.1 MUR(660)091516-22, 48-in. x 48-in. x 4.5-in.
 - 8.1.2.2 MUR(660)091516-24, 48-in. x 48-in. x 6.5-in.
- 8.1.3** ASTM E 72-15 Section 9, Axial Load, , 6/17/16 NTA, Inc. [FBC:TST3478], Test Report Numbers:
- 8.1.3.1 MUR(660)092815-27, 48-in. x 96-in. x 4.5-in.
 - 8.1.3.2 MUR(660)092815-28, 48-in. x 96-in. x 6.5-in.
 - 8.1.3.3 MUR(660)092815-29, 48-in. x 168-in. x 4.5-in.
 - 8.1.3.4 MUR(660)092815-30, 48-in. x 192-in. x 5.5-in.
 - 8.1.3.5 MUR(660)092815-31, 48-in. x 216-in. x 6.5-in.
- 8.1.4** ASTM E72-10 Section 14, Racking Load, 06/17/2016, NTA, Inc. [FBC:TST3478], Test Report Numbers:
- 8.1.4.1 MUR(660)092815-32, Single Bottom Plate 06/17/2016
 - 8.1.4.2 MUR(660)122115-16, Double Bottom Plate 06/17/2016
- 8.1.5** ASTM E72-10 Section 14, Racking Load, 11/22/17, NTA, Inc. [FBC:TST3478], Test Report Numbers:
- 8.1.5.1 MUR(660)091516-28, Single Bottom Plate
 - 8.1.5.2 MUR(660)091516-29, Double Bottom Plate
- 8.1.6** MUR(660)092815-21, ASTM E 661-03(2015), Concentrated Load, 06/17/2016, NTA, Inc. [FBC:TST3478]

This Engineering Evaluation Report is intended to indicate that the Evaluator has evaluated the product(s) herein based on the information available at the time of report issuance. The Evaluator reserves the right to modify, amend or withdrawal this report at any time based on information that becomes available subsequent to the issuance of this report. The Evaluator makes no warranty, either expressed or implied, regarding the product covered by this report.

8.1.7 MUR(660)092815-34 Various Tests evaluating properties of polyurethane core material 06/17/2016, NTA, Inc. [FBC:TST3478] Including:

- 8.1.7.1 ASTM C272-12 Water Absorption
- 8.1.7.2 ASTM D1622-14 Density
- 8.1.7.3 ASTM D1621-10 Compressive Strength
- 8.1.7.4 ASTM C203-05a(2012) Flexural Strength
- 8.1.7.5 ASTM D1623-09 Tensile Strength
- 8.1.7.6 ASTM C273-11 Shear Strength
- 8.1.7.7 ASTM D1623-09 Adhesion
- 8.1.7.8 ASTM E96-14 Water Vapor Permeance
- 8.1.7.9 ASTM D2126-09 Dimensional Stability

8.1.8 MUR(660)092815-35, ASTM C480-08 Creep Resistance. 06/17/2016, NTA, Inc. [FBC:TST3478]

8.1.9 F3569.01-121-24, NFPA 286-15 Contribution of wall and Ceiling Interior Finish to Room Fire Growth. 01/29/2016. Intertek-ATI, IAS Lab Certification No. TL-144

Table 1: Basic Properties¹

Property	Strong-Axis Bending
Allowable Tensile Stress, F_t (psi)	495
Allowable Compressive Stress, F_c (psi)	619
Elastic Modulus (Bending), E_b (psi)	1,002,768
Shear Modulus, G (psi)	355
Allowable Core Shear Stress, F_v (psi)	6.5
Core Compressive Modulus, E_c (psi)	340
Reference Depth, h_o (in.)	4.500
Shear Depth Factor Exponent, m	0.977

¹ All properties are based on a minimum panel width of 24-in.

Table 2: Section Properties

Panel Thickness, h (in.)	Core Thickness, c (in.)	Dead Weight, w_d (psf)	Facing Area, A_f (in. ² /ft)	Shear Area, A_v (in. ² /ft)	Moment of Inertia, I (in. ⁴ /ft)	Section Modulus, S (in. ³ /ft)	Radius of Gyration, r (in.)	Centroid-to-Facing Dist., y_c (in.)
4.625	3.75	3.95	10.5	50.3	46.0	19.9	2.09	2.31
5.625	4.75	4.15	10.5	62.3	70.6	25.1	2.59	2.81
6.625	5.75	4.35	10.5	74.3	100.5	30.3	3.09	3.31

This Engineering Evaluation Report is intended to indicate that the Evaluator has evaluated the product(s) herein based on the information available at the time of report issuance. The Evaluator reserves the right to modify, amend or withdrawal this report at any time based on information that becomes available subsequent to the issuance of this report. The Evaluator makes no warranty, either expressed or implied, regarding the product covered by this report.

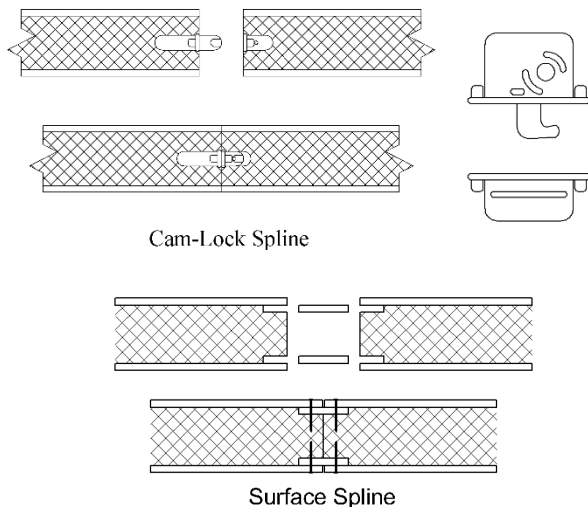

Figure 1: SIP Spline Types

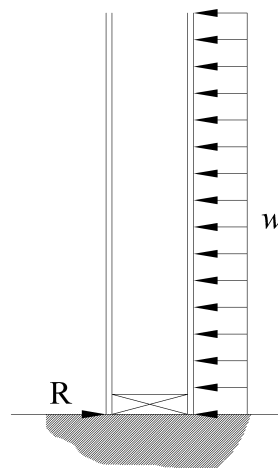

Figure 2: Zero Bearing Support

Table 3: Allowable Uniform Transverse Loads (psf)^{1, 3, 4}

Span (ft)	4-5/8-in. thick SIP			5-5/8-in. thick SIP			6-5/8-in. thick SIP		
	Deflection Limit ²			Deflection Limit ²			Deflection Limit ²		
	L/180	L/240	L/360	L/180	L/240	L/360	L/180	L/240	L/360
4	175.5	131.6	87.8	222.6	166.9	111.3	247.6	202.3	134.8
6	105.5	79.1	52.7	134.3	102.2	68.1	141.5	125.4	83.6
8	69.5	52.2	34.8	91.7	68.8	45.8	99.0	85.7	57.1
10	48.1	36.1	24.1	64.8	48.6	32.4	76.2	61.5	41.0
12	34.5	25.8	17.2	47.2	35.4	23.6	60.7	45.5	30.3
14	25.3	19.0	12.7	35.3	26.5	17.6	45.9	34.5	23.0
16	19.0	14.3	9.5	26.9	20.2	13.4	35.4	26.6	17.7
18	14.6	10.9	7.3	20.9	15.6	10.4	27.8	20.8	13.9
20	11.3	8.5	5.7	16.4	12.3	8.2	22.1	16.5	11.0
22	9.0	6.7	4.5	13.1	9.8	6.6	17.8	13.3	8.9
24	7.2	5.4	3.6	10.6	8.0	5.3	14.5	10.8	7.2

¹ Table values assume a simply supported panel with 1.1/2-in. of continuous bearing on facing at supports ($C_v = 1.0$) with solid wood plates at bearing locations. Values do not include the dead weight of the panel. For wall panel capacities utilizing a zero bearing configuration (Figure 2), the allowable load shall be determined using $C_v = 0.8$.

² Deflection limit shall be selected by building designer based on the serviceability requirements of the structure and the requirements of adopted building code. Values are based on loads of short duration only and do not consider the effects of creep.

³ Permanent loads, such as dead load, shall not exceed 0.50 times the tabulated load.

⁴ Design wind loads determined in accordance with ASCE 7-16 (strength design).

**Table 4: Allowable In-Plane Shear Strength (Pounds per Foot)
 for SIP Shear Walls (Wind and Seismic Loads in Seismic Design Categories A, B and C)^{1, 2}**

Spline Type ⁴	Minimum Nominal SIP Thickness (in.)	Minimum Facing Connections ^{2,4}			Shear Strength (plf)
		Chord ²	Plate ²	Spline ³	
Cam-lock	4-5/8	0.131-in. x 2-1/2-in. coated nails, 6-in. on center	0.131-in. x 2-1/2-in. coated nails, 3-in. on center	Cam-locks spaced 24-in. on center	150
	4-5/8 ⁵	0.131-in. x 2-1/2-in. coated nails, 6-in. on center	0.131-in. x 2-1/2-in. coated nails, 3-in. on center	Cam-locks spaced 24-in. on center	360
	4-5/8 ⁶	0.131-in. x 2-1/2-in. coated nails, 6-in. on center	0.131-in. x 2-1/2-in. coated nails, 3-in. on center	Cam-locks spaced 24-in. on center Dow Great Stuff Pro® Insulating Foam Sealant (3) lines of 5/8-in. diameter bead at SIP joint See Figure 3	400
	4-5/8 ⁵	0.131-in. x 2-1/2-in. coated nails, 6-in. on center	0.131-in. x 2-1/2-in. coated nails, 3-in. on center	Cam-locks spaced 24-in. on center Dow Great Stuff Pro® Insulating Foam Sealant (3) lines of 5/8-in. diameter bead at SIP joint See Figure 4	475

¹ Maximum shear wall dimensions ratio shall not exceed 2:1 (height: width) for resisting wind or seismic loads.

² Chords, hold downs and connections to other structural elements must be designed by a registered design professional in accordance with accepted engineering practice.

³ Spline type at interior panel-to-panel joints only. Solid chord members are required at each end of each shear wall segment.

⁴ Required connections must be made on each side of the panel. Dimensional or engineered lumber shall have an equivalent specific gravity of 0.42 or greater.

⁵ Assembly includes a second embedded bottom plate of 1-1/8-in. minimum thickness dimensional or engineered lumber with a specific gravity of 0.42 secured to the panel facing using 0.131-in. x 2-1/2-in. nails spaced 3-in. on center or an approved equivalent fastener and secured to the first bottom plate using #8 - 9 x 3-in. Wood Screws 6-in. on-center staggered. A second top plate of 1-1/8-in. minimum thickness dimensional or engineered lumber with a specific gravity of 0.42 that is cut to the full thickness of the panel shall be secured to the first top plate using the top plate using #8 - 9 x 3-in. Wood Screws 6-in. on-center staggered.

⁶ A second top plate of 1-1/8-in. minimum thickness dimensional or engineered lumber with a specific gravity of 0.42 that is cut to the full thickness of the panel shall be secured to the first top plate using 0.162-in. x 3-1/2-in. nails or an approved equivalent fastener.

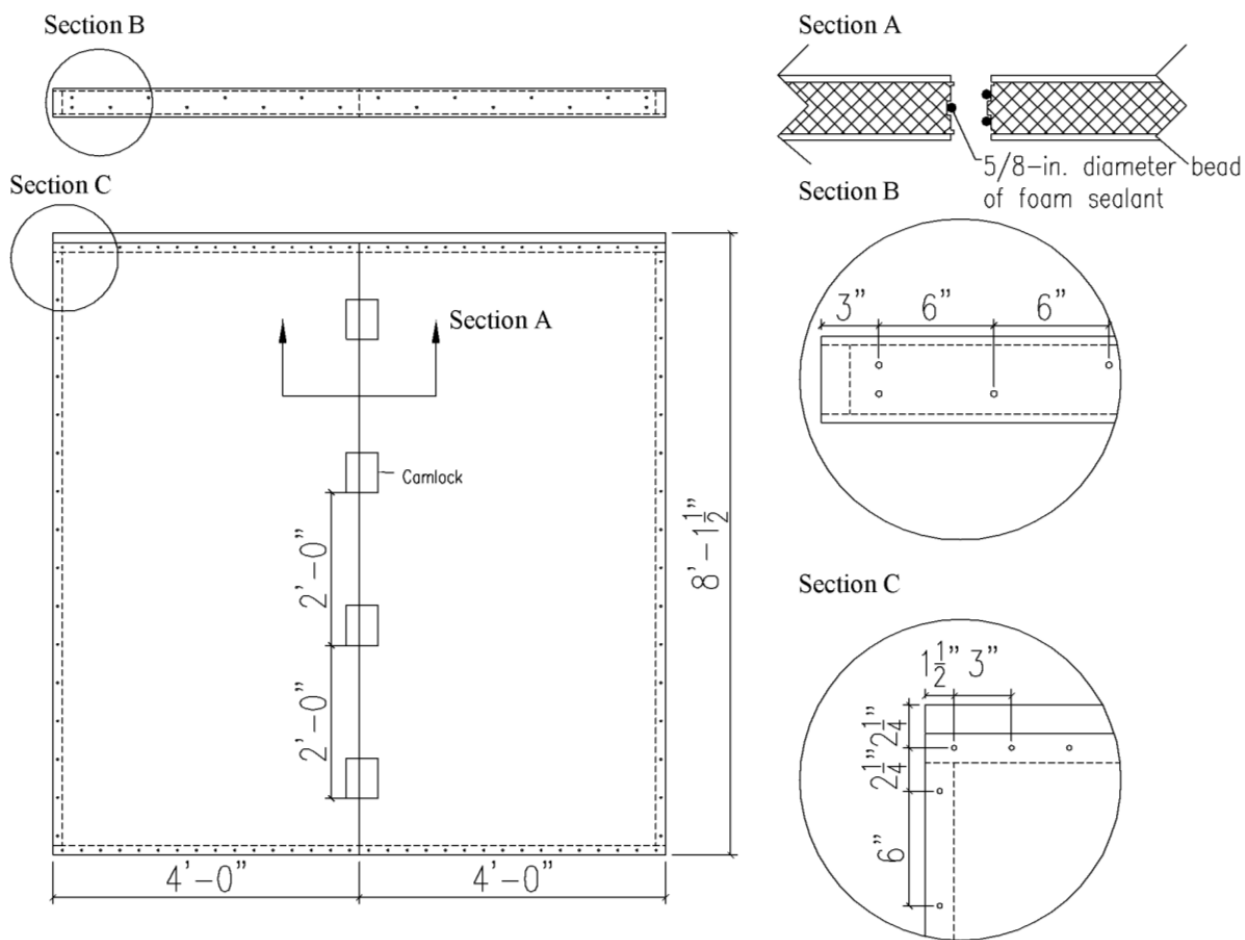

Figure 3: Shear wall construction drawing, single bottom plate

This Engineering Evaluation Report is intended to indicate that the Evaluator has evaluated the product(s) herein based on the information available at the time of report issuance. The Evaluator reserves the right to modify, amend or withdrawal this report at any time based on information that becomes available subsequent to the issuance of this report. The Evaluator makes no warranty, either expressed or implied, regarding the product covered by this report.

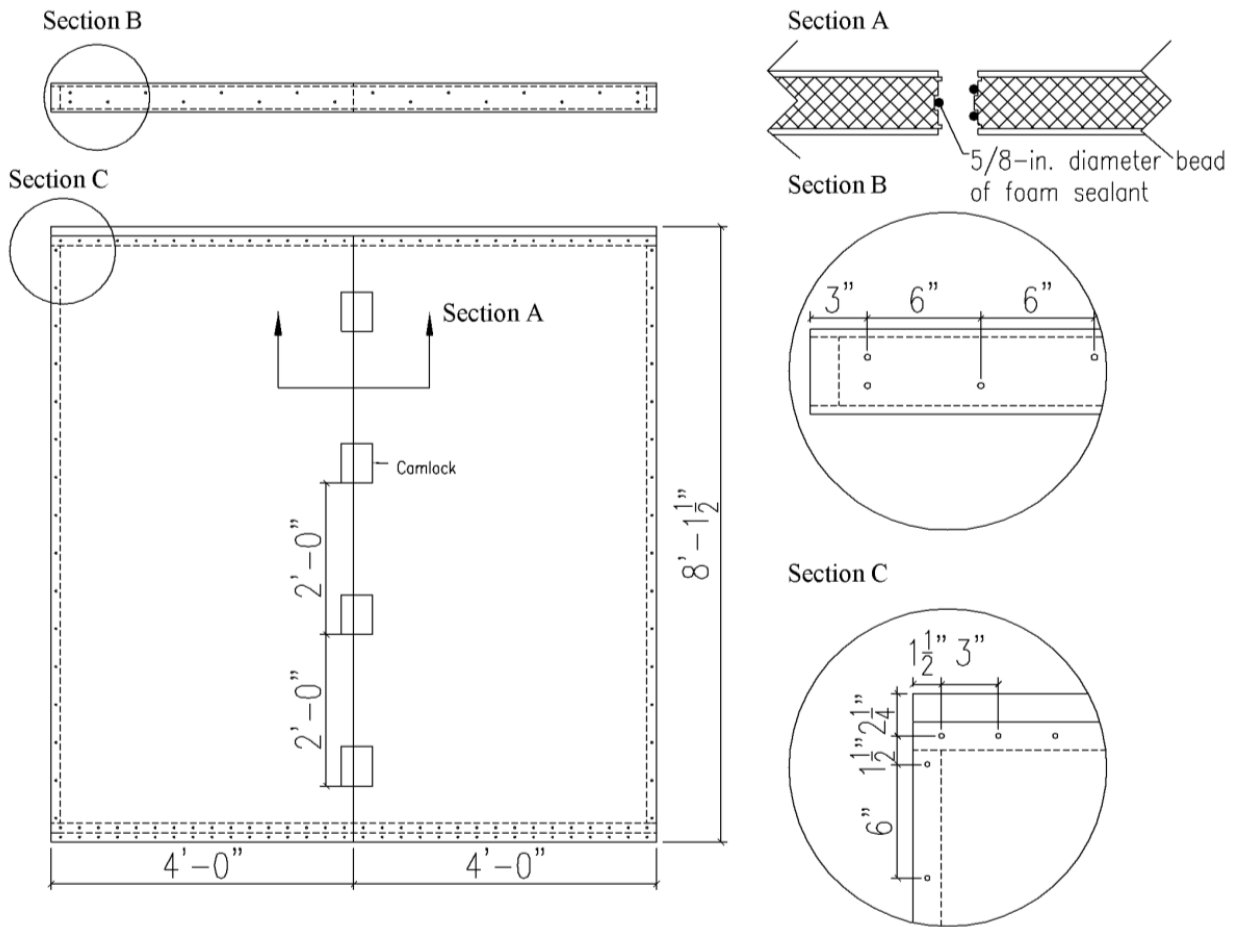

Figure 4: Shear wall construction drawing, double bottom plate

This Engineering Evaluation Report is intended to indicate that the Evaluator has evaluated the product(s) herein based on the information available at the time of report issuance. The Evaluator reserves the right to modify, amend or withdrawal this report at any time based on information that becomes available subsequent to the issuance of this report. The Evaluator makes no warranty, either expressed or implied, regarding the product covered by this report.

Table 5: Allowable Combined Axial and Transverse Loads for 4-5/8-in. thickness SIPs^{1, 2, 3, 4, 5}

Uniform Transverse Load (psf)	Span (ft)								
	8	10	12	14	16	18	20	22	24
	Panel Dead Weight (plf)								
	28.2	35.2	42.3	49.3	56.4	63.4	70.5	77.5	84.6
Allowable Axial Load (plf)									
0	4050	3640	3140	2690	--	--	--	--	--
10	3450 ^G	2970 ^G	2510 ^G	1980 ^E	--	--	--	--	--
25	2980 ^E	2110 ^D	1180 ^C	--	--	--	--	--	--
30	2760 ^D	1690 ^C	700 ^C	--	--	--	--	--	--
55	1070 ^C	--	--	--	--	--	--	--	--
60	730 ^B	--	--	--	--	--	--	--	--

¹ Permanent loads, such as dead load, shall not exceed 0.50 times the tabulated load.

² All values are for normal duration and may not be increased for other durations.

³ Axial loads shall be applied concentrically to the top of the panel through repetitive members spaced not more than 24-in. on center. Such members shall be fastened to a rim board or similar member to distribute along the top of the SIP.

⁴ The ends of both facings must bear on the supporting foundation or structure to achieve the tabulated axial loads.

⁵ When noted with the following superscript notes, values exceed the specified deflection ratio: ^AL/120, ^BL/180, ^CL/240, ^DL/360, ^EL/480, ^FL/600, ^GL/720. When the value is presented as a double dash (--), the value either is beyond the scope of the evaluation or exceeds the L/120 deflection ratio.

Table 6: Allowable Combined Axial and Transverse Loads for 5-5/8-in. thickness SIPs^{1, 2, 3, 4, 5}

Uniform Transverse Load (psf)	Span (ft)								
	8	10	12	14	16	18	20	22	24
	Panel Dead Weight (plf)								
	29.7	37.1	44.5	51.9	59.3	66.7	74.2	81.6	89
Allowable Axial Load (plf)									
0	4300	4100	3860	3580	3260	--	--	--	--
10	3930 ^G	3560 ^G	3160 ^G	2760 ^G	2380 ^E	--	--	--	--
25	3500 ^F	3000 ^E	2460 ^D	1500 ^C	630 ^B	--	--	--	--
30	3370 ^E	2840 ^D	1980 ^C	950 ^C	--	--	--	--	--
55	2540 ^C	1000 ^B	--	--	--	--	--	--	--
60	2200 ^C	580 ^B	--	--	--	--	--	--	--

See Table 5 for notes.



Table 7: Allowable Combined Axial and Transverse Loads for 6-5/8-in. thickness SIPs^{1, 2, 3, 4, 5}

Uniform Transverse Load (psf)	Span (ft)								
	8	10	12	14	16	18	20	22	24
	Panel Dead Weight (plf)								
	31.1	38.9	46.7	54.5	62.3	70	77.8	85.6	93.4
Allowable Axial Load (plf)									
0	4440	4310	4140	3940	3710	3450	--	--	--
10	4170 ^G	3910 ^G	3590 ^G	3250 ^G	2900 ^G	2550 ^F	--	--	--
25	3820 ^G	3410 ^F	2950 ^E	2490 ^D	1760 ^C	860 ^C	--	--	--
30	3710 ^G	3250 ^E	2760 ^D	2190 ^C	1130 ^C	--	--	--	--
55	3210 ^D	2420 ^C	850 ^B	--	--	--	--	--	--
60	3110 ^D	2000 ^C	--	--	--	--	--	--	--

See Table 5 for notes.